

Computer Architecture

Spring 2016

Lecture 17: Static Scheduling & VLIW

Shuai Wang

Department of Computer Science and Technology

Nanjing University

[Slides adapted from CS 252, UC Berkeley]

VLIW: Very Long Instruction Word

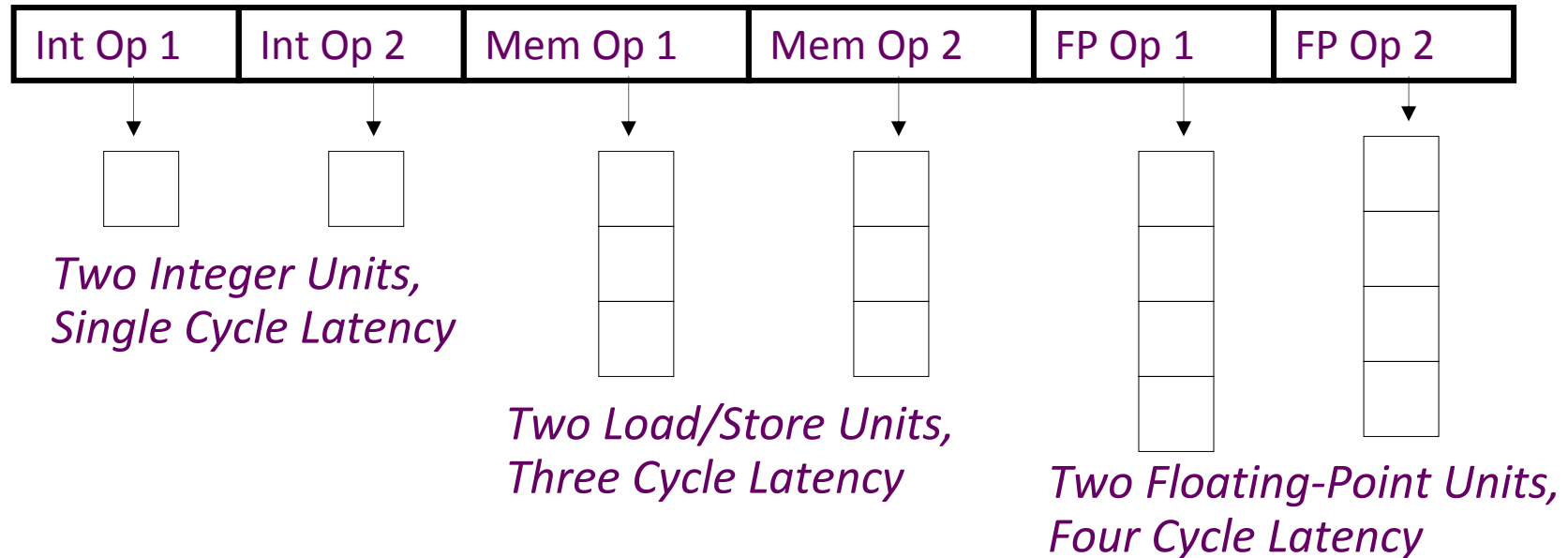

- Multiple operations packed into one instruction
- Each operation slot is for a fixed function
- Constant operation latencies are specified
- Architecture requires guarantee of:
 - Parallelism within an instruction => no cross-operation RAW check
 - No data use before data ready => no data interlocks

Early VLIW Machines

- FPS AP120B (1976)
 - scientific attached array processor
 - first commercial wide instruction machine
 - hand-coded vector math libraries using software pipelining and loop unrolling
- Multiflow Trace (1987)
 - commercialization of ideas from Fisher's Yale group including "trace scheduling"
 - available in configurations with 7, 14, or 28 operations/instruction
 - 28 operations packed into a 1024-bit instruction word
- Cydrome Cydra-5 (1987)
 - 7 operations encoded in 256-bit instruction word
 - rotating register file

VLIW Compiler Responsibilities

- Schedule operations to maximize parallel execution
- Guarantees intra-instruction parallelism
- Schedule to avoid data hazards (no interlocks)
 - Typically separates operations with explicit NOPs

Loop Execution

```
for (i=0; i<N; i++)
    B[i] = A[i] + C;
```

↓ *Compile*

```
loop: fld f1, 0(x1)
      add x1, 8
      fadd f2, f0, f1
      fsd f2, 0(x2)
      add x2, 8
      bne x1, x3,
loop
```

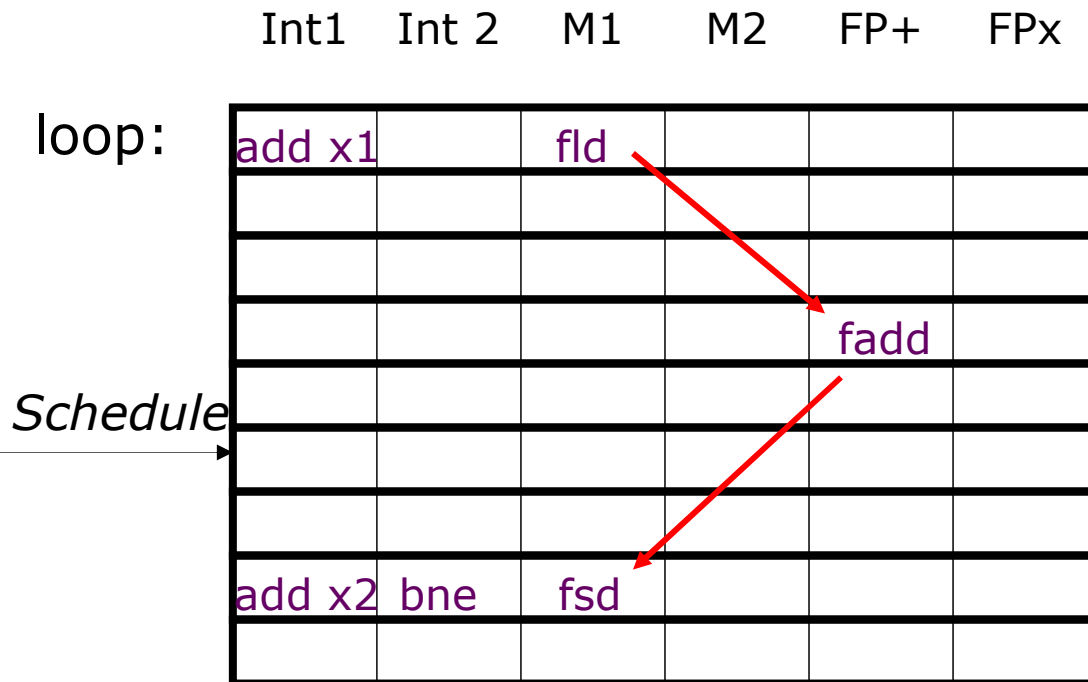

How many FP ops/cycle?

1 fadd / 8 cycles = 0.125

Loop Unrolling

```
for (i=0; i<N; i++)  
    B[i] = A[i] + C;
```

Unroll inner loop to perform 4 iterations at once

```
for (i=0; i<N; i+=4)  
{  
    B[i]    = A[i] + C;  
    B[i+1] = A[i+1] + C;  
    B[i+2] = A[i+2] + C;  
    B[i+3] = A[i+3] + C;  
}
```

Need to handle values of N that are not multiples of unrolling factor with final cleanup loop

Scheduling Loop Unrolled Code

Unroll 4 ways

```

loop: fld f1, 0(x1)
      fld f2, 8(x1)
      fld f3, 16(x1)
      fld f4, 24(x1)
      add x1, 32
      fadd f5, f0, f1
      fadd f6, f0, f2
      fadd f7, f0, f3
      fadd f8, f0, f4
      fsd f5, 0(x2)
      fsd f6, 8(x2)
      fsd f7, 16(x2)
      fsd f8, 24(x2)
      add x2, 32
      bne x1, x3, loop
    
```

Schedule →

loop:

	Int1	Int 2	M1	M2	FP+	FPx
			fld f1			
			fld f2			
			fld f3			
add x1			fld f4		fadd f5	
					fadd f6	
					fadd f7	
					fadd f8	
			fsd f5			
			fsd f6			
			fsd f7			
add x2	bne	fsd f8				

How many FLOPS/cycle?

$$4 \text{ fadds} / 11 \text{ cycles} = 0.36$$

Software Pipelining

Unroll 4 ways first

```

loop: fld f1, 0(x1)
      fld f2, 8(x1)
      fld f3, 16(x1)
      fld f4, 24(x1)
      add x1, 32
      fadd f5, f0, f1
      fadd f6, f0, f2
      fadd f7, f0, f3
      fadd f8, f0, f4
      fsd f5, 0(x2)
      fsd f6, 8(x2)
      fsd f7, 16(x2)
      fsd f8, -8(x2)
      add x2, 32
      fsd f8, -8(x2)
      bne x1, x3, loop
    
```

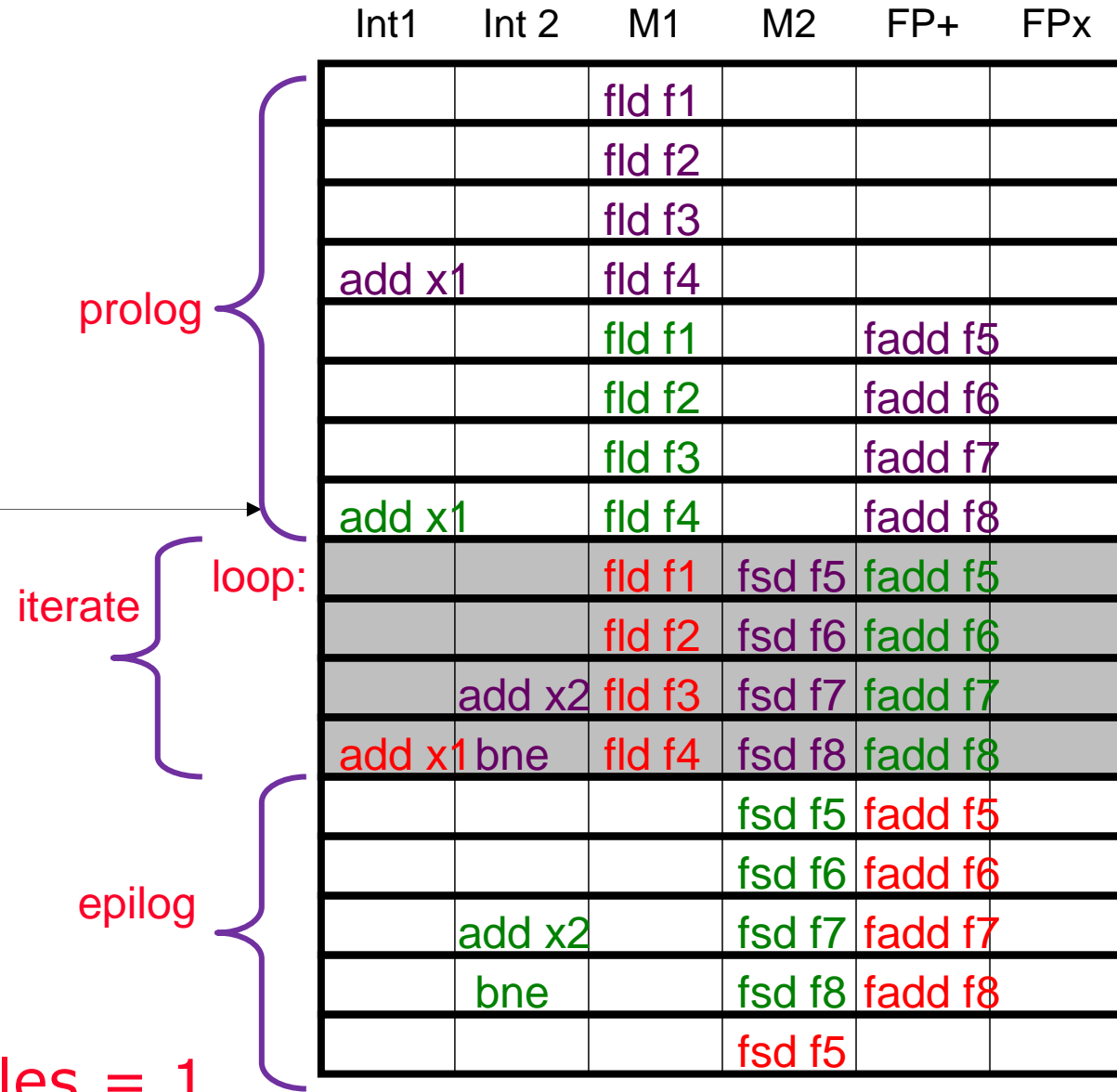

How many FLOPS/cycle?

4 fadds / 4 cycles = 1

Software Pipelining vs. Loop Unrolling

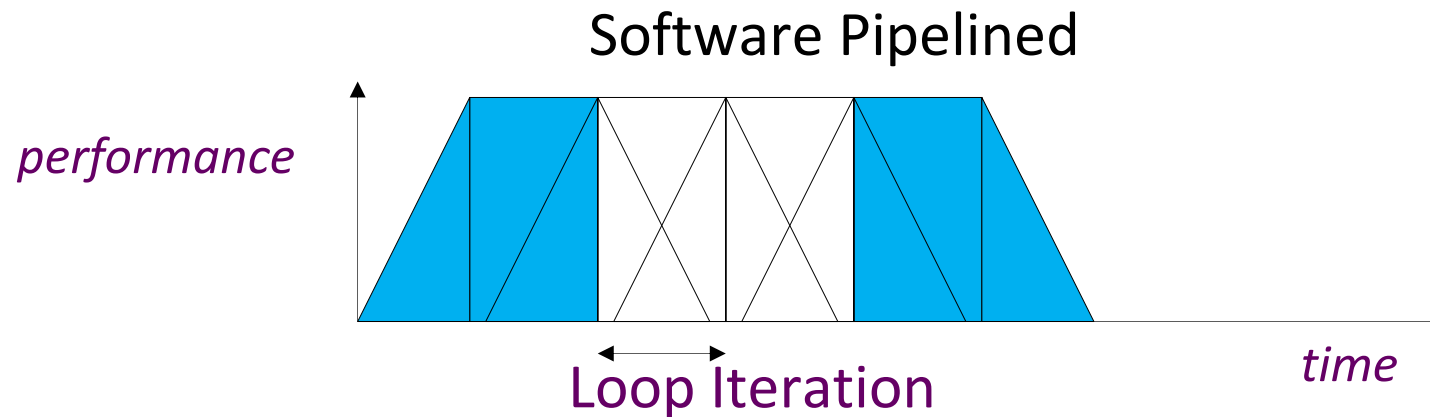
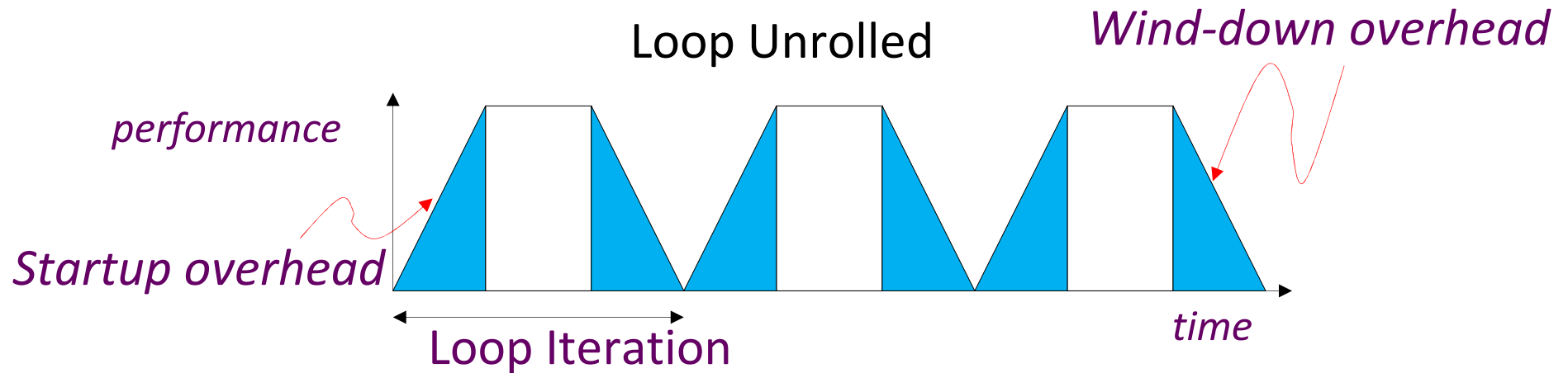

Software pipelining pays startup/wind-down costs only once per loop, not once per iteration

What if there are no loops?

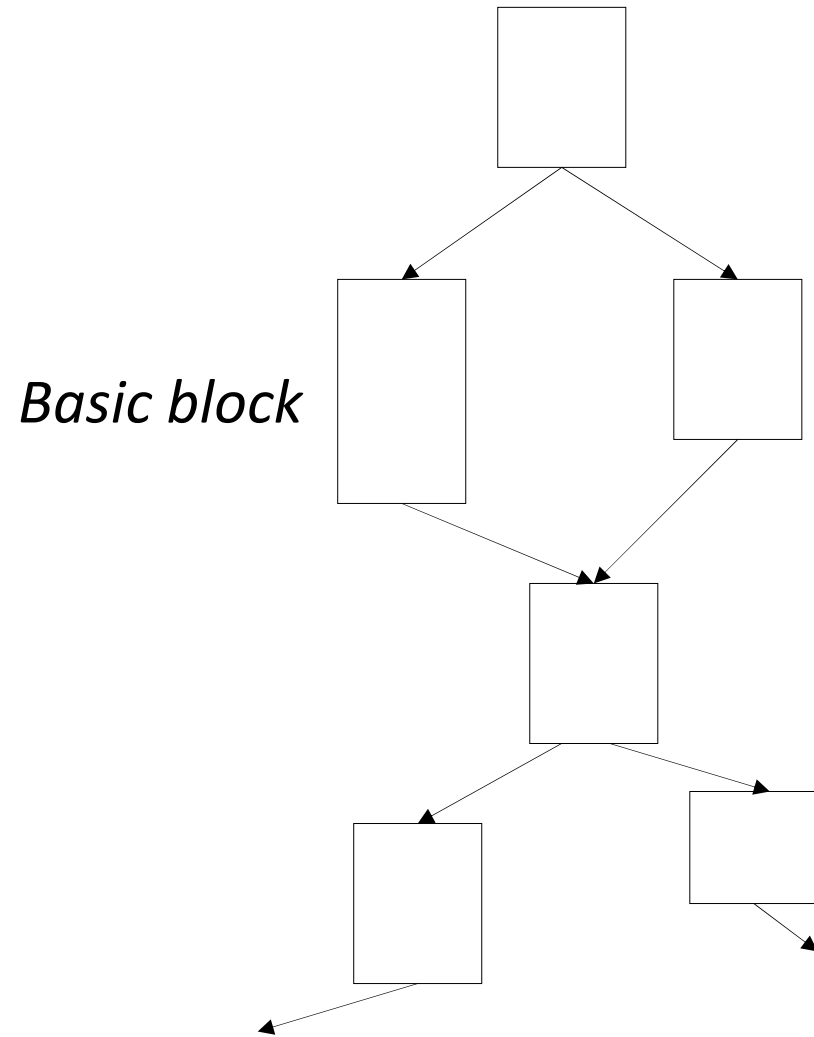

- Branches limit basic block size in control-flow intensive irregular code
- Difficult to find ILP in individual basic blocks

Trace Scheduling [Fisher, Ellis]

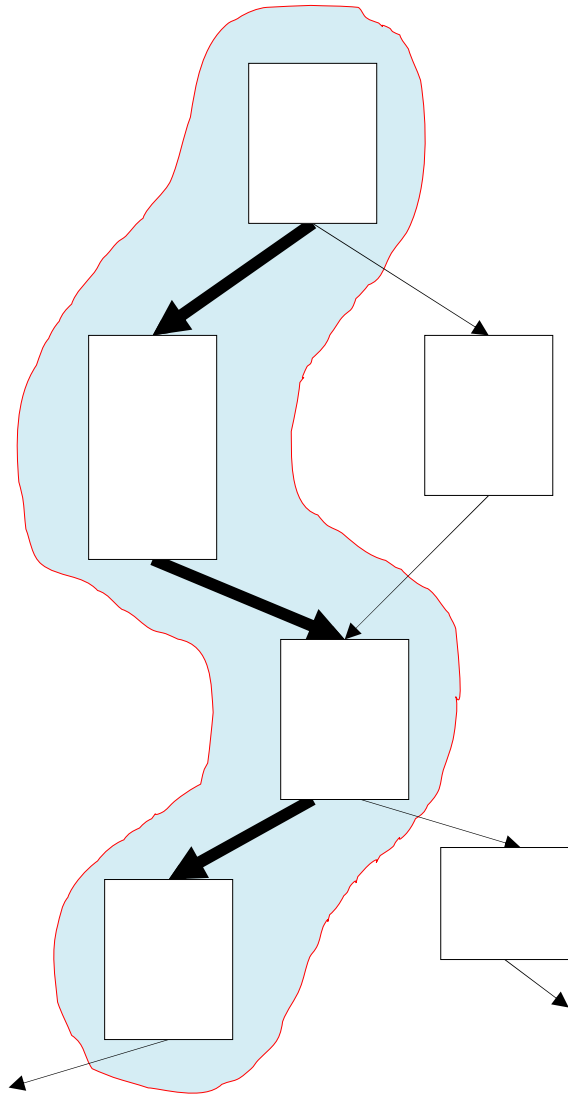

- Pick string of basic blocks, a trace, that represents most frequent branch path
- Use profiling feedback or compiler heuristics to find common branch paths
- Schedule whole “trace” at once
- Add fixup code to cope with branches jumping out of trace

Problems with “Classic” VLIW

- Object-code compatibility
 - have to recompile all code for every machine, even for two machines in same generation
- Object code size
 - instruction padding wastes instruction memory/cache
 - loop unrolling/software pipelining replicates code
- Scheduling variable latency memory operations
 - caches and/or memory bank conflicts impose statically unpredictable variability
- Knowing branch probabilities
 - Profiling requires an significant extra step in build process
- Scheduling for statically unpredictable branches
 - optimal schedule varies with branch path

VLIW Instruction Encoding

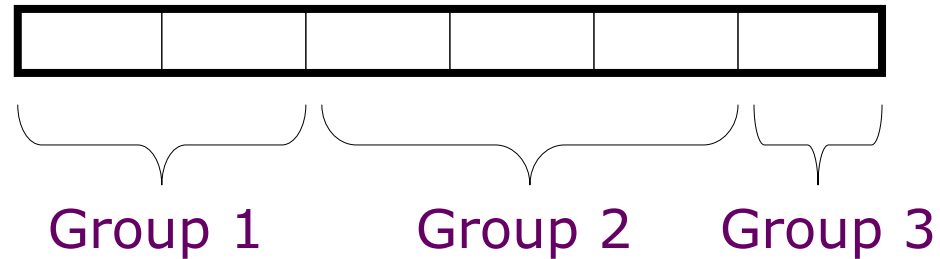

- Schemes to reduce effect of unused fields
 - Compressed format in memory, expand on I-cache refill
 - used in Multiflow Trace
 - introduces instruction addressing challenge
 - Mark parallel groups
 - used in TMS320C6x DSPs, Intel IA-64
 - Provide a single-op VLIW instruction
 - Cydra-5 UniOp instructions

Intel Itanium, EPIC IA-64

- EPIC is the style of architecture (cf. CISC, RISC)
 - Explicitly Parallel Instruction Computing (really just VLIW)
- IA-64 is Intel's chosen ISA (cf. x86, MIPS)
 - IA-64 = Intel Architecture 64-bit
 - An object-code-compatible VLIW
- Merced was first Itanium implementation (cf. 8086)
 - First customer shipment expected 1997 (actually 2001)
 - McKinley, second implementation shipped in 2002
 - Recent version, Poulson, eight cores, 32nm, announced 2011

Eight Core Itanium “Poulson” [Intel 2011]

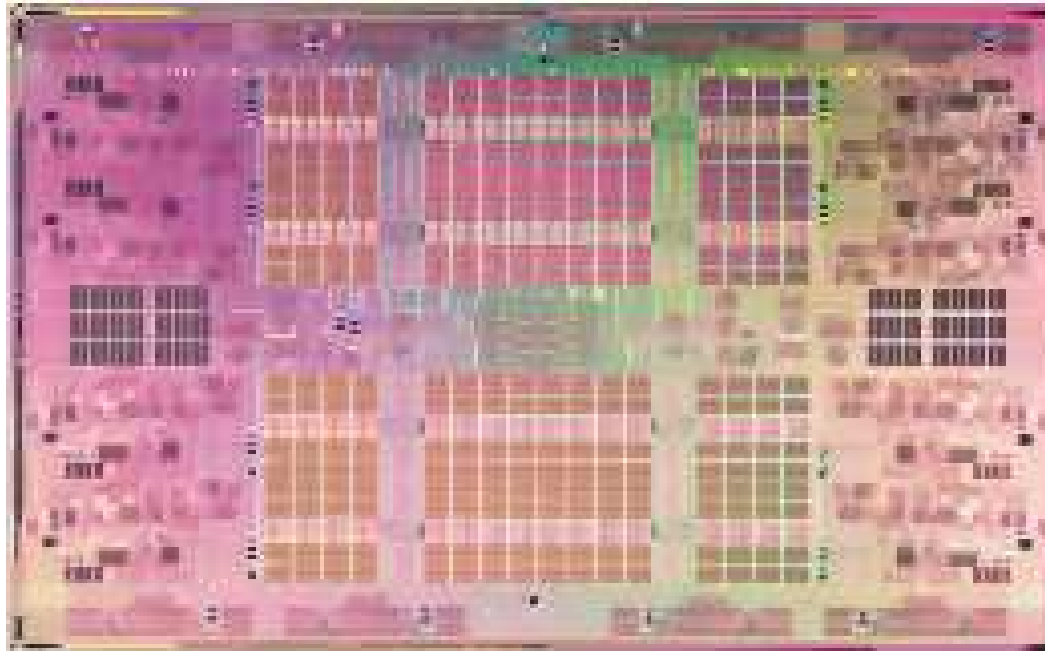

- 8 cores
- 1-cycle 16KB L1 I&D caches
- 9-cycle 512KB L2 I-cache
- 8-cycle 256KB L2 D-cache
- 32 MB shared L3 cache
- 544mm² in 32nm CMOS
- Over 3 billion transistors
- Cores are 2-way multithreaded
- 6 instruction/cycle fetch
 - Two 128-bit bundles
- Up to 12 insts/cycle execute

IA-64 Instruction Format



128-bit instruction bundle

- Template bits describe grouping of these instructions with others in adjacent bundles
- Each group contains instructions that can execute in parallel

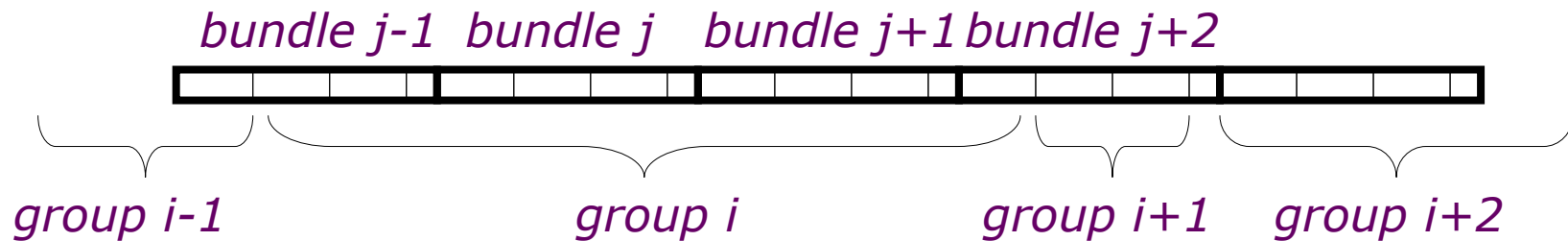

IA-64 Registers

- 128 General Purpose 64-bit Integer Registers
- 128 General Purpose 64/80-bit Floating Point Registers
- 64 1-bit Predicate Registers

- GPRs “rotate” to reduce code size for software pipelined loops
 - Rotation is a simple form of register renaming allowing one instruction to address different physical registers on each iteration

Rotating Register Files

Problems: Scheduled loops require lots of registers,
Lots of duplicated code in prolog, epilog

Solution: Allocate new set of registers for each loop iteration

Rotating Register File

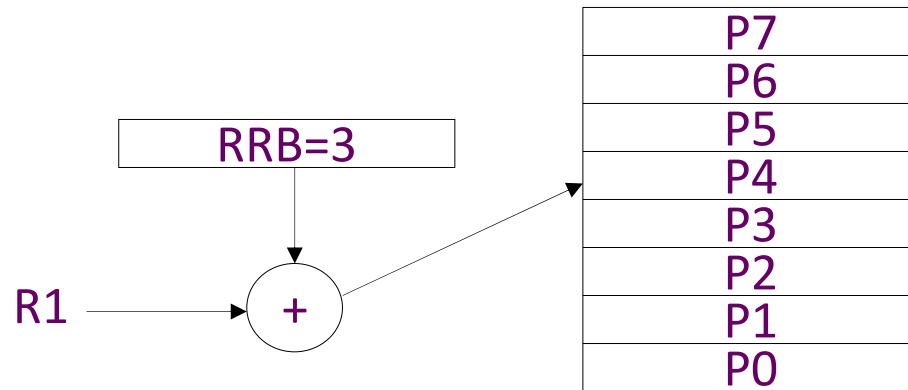

Rotating Register Base (RRB) register points to base of current register set. Value added on to logical register specifier to give physical register number. Usually, split into rotating and non-rotating registers.

Rotating Register File

(Previous Loop Example)

Three cycle load latency
 encoded as difference of 3
 in register specifier
 number ($f4 - f1 = 3$)

Four cycle fadd latency
 encoded as difference of 4
 in register specifier
 number ($f9 - f5 = 4$)

ld f1, ()	fadd f5, f4, ...	sd f9, ()	bloop
-----------	------------------	-----------	-------

ld P9, ()	fadd P13, P12,	sd P17, ()	bloop	RRB=8
ld P8, ()	fadd P12, P11,	sd P16, ()	bloop	RRB=7
ld P7, ()	fadd P11, P10,	sd P15, ()	bloop	RRB=6
ld P6, ()	fadd P10, P9,	sd P14, ()	bloop	RRB=5
ld P5, ()	fadd P9, P8,	sd P13, ()	bloop	RRB=4
ld P4, ()	fadd P8, P7,	sd P12, ()	bloop	RRB=3
ld P3, ()	fadd P7, P6,	sd P11, ()	bloop	RRB=2
ld P2, ()	fadd P6, P5,	sd P10, ()	bloop	RRB=1

IA-64 Predicated Execution

Problem: Mispredicted branches limit ILP

Solution: Eliminate hard to predict branches with predicated execution

- Almost all IA-64 instructions can be executed conditionally under predicate
- Instruction becomes NOP if predicate register false

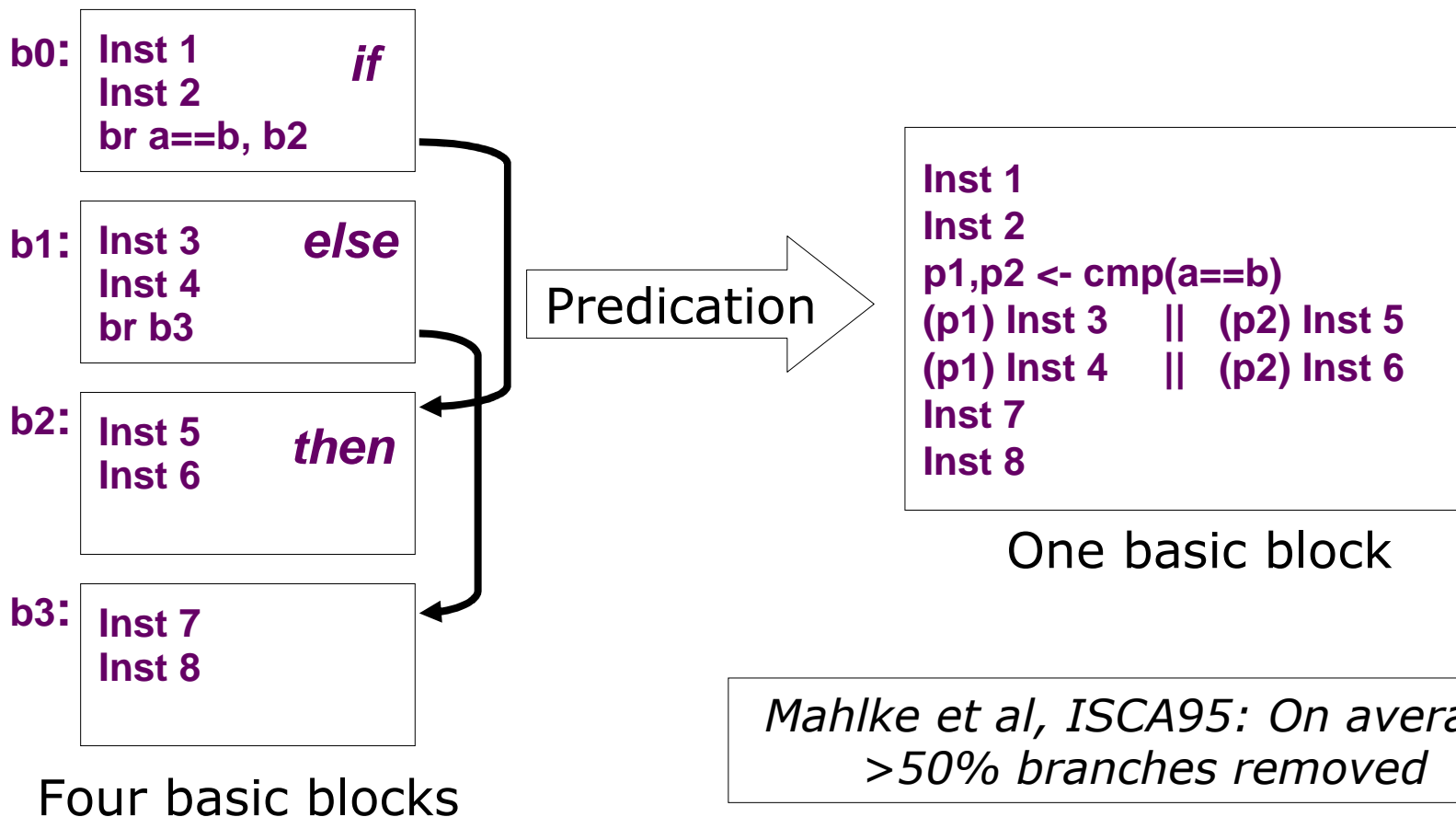

IA-64 Speculative Execution

Problem: Branches restrict compiler code motion

Solution: Speculative operations that don't cause exceptions

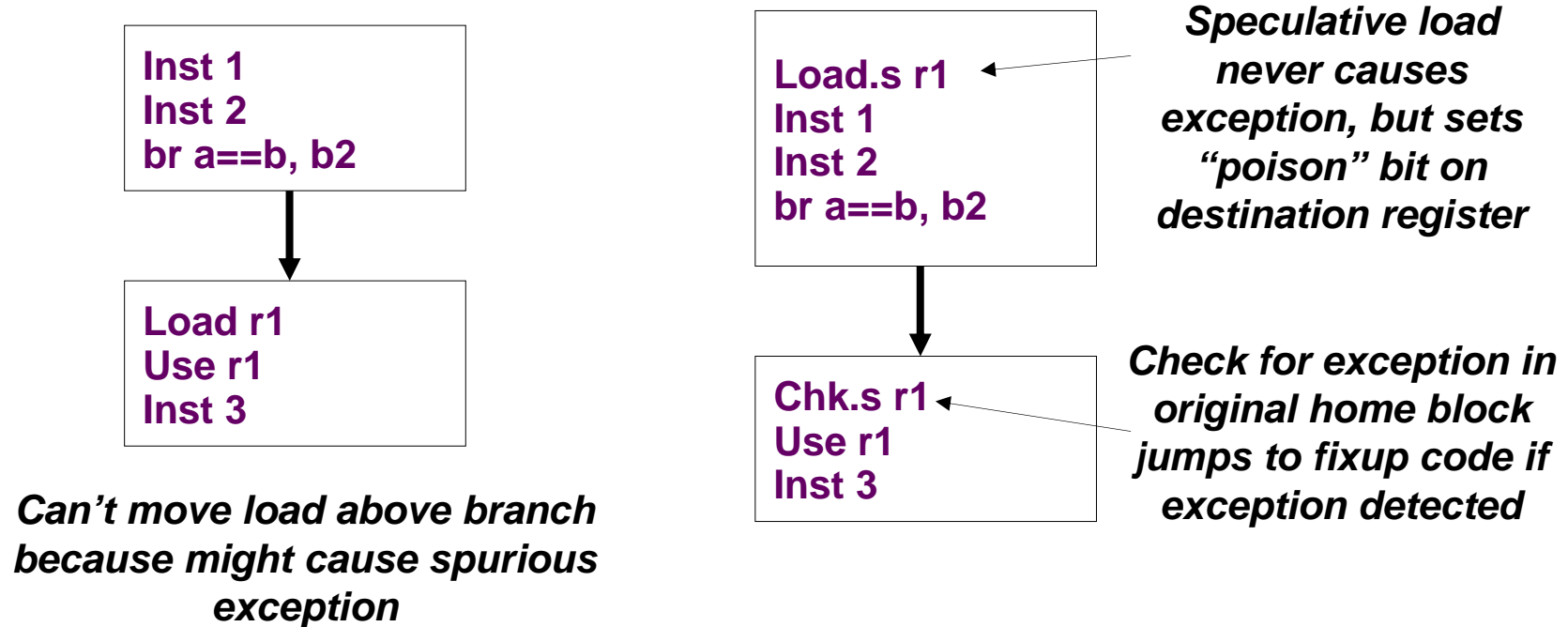

Particularly useful for scheduling long latency loads early

IA-64 Data Speculation

Problem: Possible memory hazards limit code scheduling

Solution: Hardware to check pointer hazards

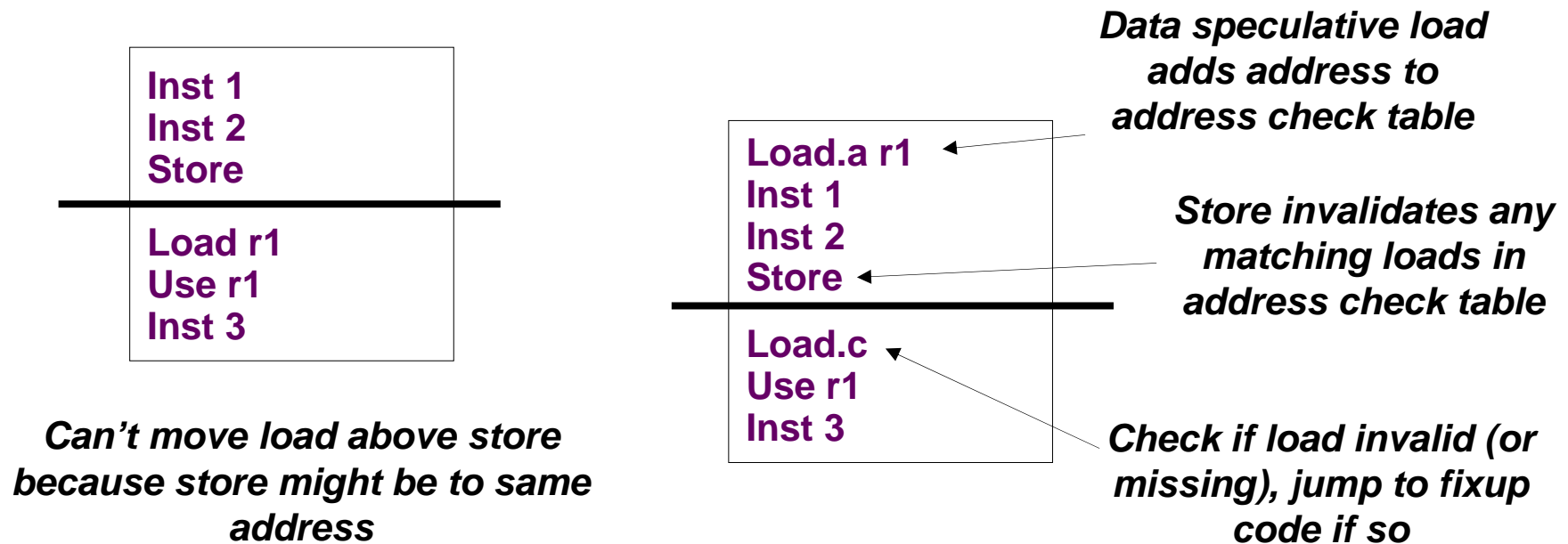

Requires associative hardware in address check table

Limits of Static Scheduling

- Unpredictable branches
- Variable memory latency (unpredictable cache misses)
- Code size explosion
- Compiler complexity
- Despite several attempts, VLIW has failed in general-purpose computing arena (so far).
 - More complex VLIW architectures close to in-order superscalar in complexity, no real advantage on large complex apps.
- Successful in embedded DSP market
 - Simpler VLIWs with more constrained environment, friendlier code.